



AlfaBlue Junior AG(H)

Air-cooled condensers – commercial range

General information & application

In addition to the well-proven AlfaBlue condenser line, the new generation of AlfaBlue Junior commercial condensers is a competitive condenser line of robust construction and high rigidity, that has every feature you need.

AlfaBlue Junior offers excellent performance especially at low air flow rates, allowing easy installation on site and an outstanding integration with other components. Highly efficient fan motors combine excellent sound characteristics and low energy consumption.

AlfaBlue Junior condensers may be used in commercial refrigeration and A/C installations.

Refrigerants	all H(C)FC
Capacities (SC2)	6.5 up to 260 kW

Coil

An innovative coil design based on 5/16" copper tubes and corrugated aluminium turbo fins provides excellent heat transfer at minimal refrigerant charge. Standard fin spacing is 2.1 mm.

Casing

The coil frame is made from AlMg₃ for protection against vibration and thermal expansion. Casing material is galvanized steel sheet, pre-painted with an epoxy finish (RAL9002). Separated fan sections.

Fan motors

High efficiency fans with innovative polymeric fan blades and low power consumption. Available in three fan diameters (400, 500 & 630 mm), different power supplies (230V, 400V, 50/60Hz) and four noise levels.

Protection class IP 54 according to DIN 40050. Integrated thermo contacts provide reliable protection against thermal overload (terminals in the box). Motors may be wired to one or more common terminal boxes.

AlfaBlue Junior AGH

A special range of High Pressure condensers is available with circuiting design optimized for refrigerant R410A. This AGH range has been specifically developed for AC applications and may be tailor made for OEM use.

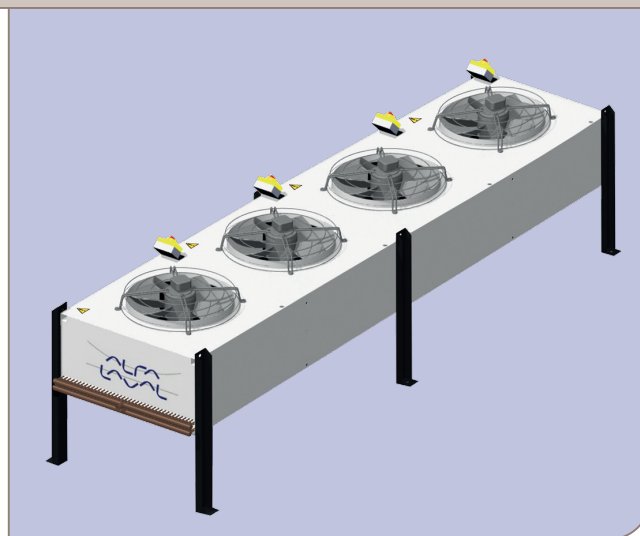

AlfaBlue Junior

Options

- EC fan motors (500 & 630 mm fans only)
- Non-standard power supply
- Fan motor switches
- Terminal box for electric power connection
- Fan speed control (230/1 and 400/3)
- Coil corrosion protection
 - Coil coating
 - Fins seawater resistant aluminium alloy 57S/5052
- Special fin spacing (2.5 and 3.2mm)
- Vibration dampers
- End covers
- Additional electrical options (selection software)

Certifications

All condenser models are "Eurovent Certify All" certified. The Alfa Laval quality system is in accordance with ISO 9001. All products are manufactured according to CE and PED rules.

Test

Each heat exchanger undergoes a pressure and leak test with dry air at 35 barg (AGH: 49 barg). It is then supplied with a nitrogen pre-charge.

Selection

Please use our AlfaSelect Air selection software for condenser selection and RCPL pricing.



Dimensions												Weight & Connections					
type	fans	L	H	W	H2	W2	M1	M2	M3	M4	M5	Coil size A		Coil size B		Coil size C	
		mm	mm	mm	mm	mm	mm	mm	mm	mm	mm	mm	kg	mm	kg	mm	kg
AG*401	1	780	712	596	555	362	630	-	-	591	215	18	16-14	19	16-14	-	-
AG*402	2	1380	712	596	555	362	1230	-	-	591	215	34	22-18	39	22-18	-	-
AG*403	3	1980	712	596	555	362	1830	-	-	591	215	43	22-18	51	28-22	-	-
AG*501	1	1105	846	868	828	428	940	-	-	868	420	39	22-20	42	22-20	47	22-20
AG*502	2	2005	846	868	828	428	1840	-	-	868	420	76	28-22	85	28-22	93	28-22
AG*503	3	2905	846	868	828	428	2740	-	-	868	420	111	35-28	123	35-28	137	35-28
AG*504	4	3805	846	868	828	428	1800	1840	-	868	420	-	-	179	42-35	192	42-35
AG*631	1	1335	1171	1210	1034	750	960	-	-	1105	660	87	22-18	93	28-22	99	28-22
AG*632	2	2335	1171	1210	1034	750	1960	-	-	1105	660	164	28-22	176	35-28	188	35-28
AG*633	3	3335	1171	1210	1034	750	2960	-	-	1105	660	242	35-28	259	42-35	277	54-42
AG*634	4	4335	1171	1210	1034	750	1960	2000	-	1105	660	318	54-42	343	54-42	366	54-42
AG*635	5	5335	1171	1210	1034	750	1960	1000	2000	1105	660	374	64-54	403	76-64	434	76-64
AG*636	6	6335	1171	1210	1034	750	1960	2000	2000	1105	660	448	76-64	484	76-64	519	76-64

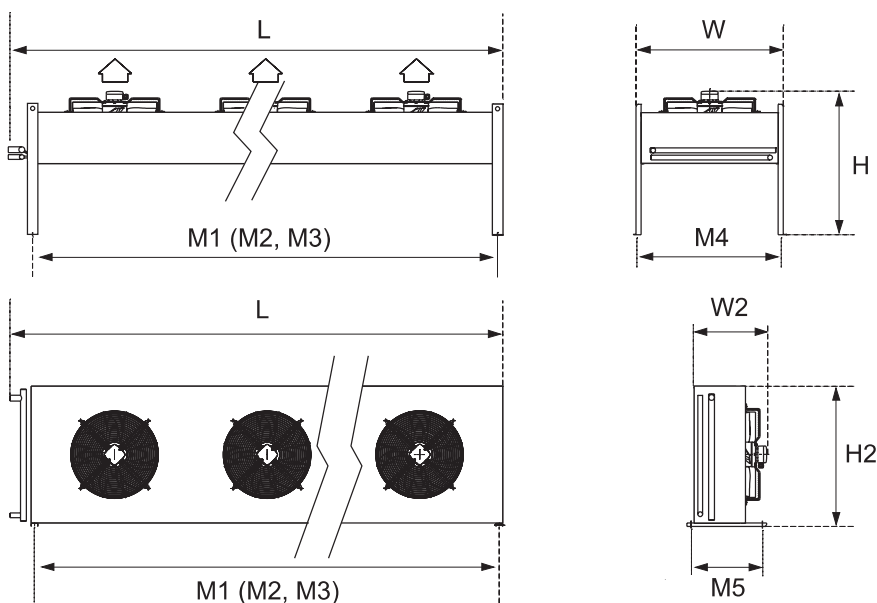

NOTE: weights for AG*6 are given for sound execution S (Standard).
Weights for executions L, Q & R are 92% of the given values.

Code description

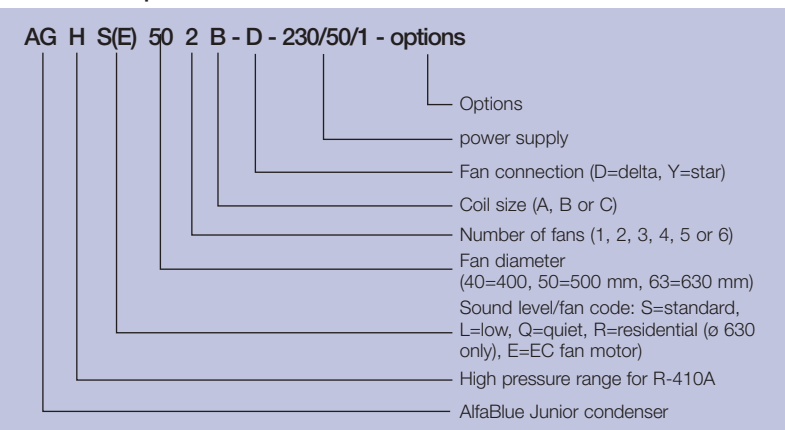

Benefits

- Reduced refrigerant charge
- Excellent sound characteristics, suitable for residential applications
- Reliable performance, Eurovent certified
- Easy installation & maintenance.
- Energy efficient - low total cost of ownership.
- Damage-proof packing in sturdy cardboard box on pallet. Bigger units in a crate and wrapped with plastic foil.
- Two-year product guarantee.

ERC00258EN 1007

Alfa Laval reserves the right to change specification without prior notification.

How to contact Alfa Laval

Up-to-date Alfa Laval contact details for all countries are always available on our website at www.alfalaval.com

